

1160 8 Ω

M17

PROFESSIONAL SERIES

6.5" Midrange Driver High Efficiency Contact Class

APPLICATIONS

Built according to PHL AUDIO Quality standards, this rugged Contact Class model is ideal for improved replacement of sound reinforcement industry standard types, bringing low harmonic distortion as well as long term reliability to the design.

DESIGN CONCEPT

PROGRESSIVE WAVE DIAPHRAGM optimized for midrange frequency domain.

The M17/E17 Series design is based on the PROGRESSIVE WAVE DIAPHRAGM mechanical behavior of the radiating area.

In this principle, the membrane is considered as a mechanical transmission line which should receive a constant given velocity together with critical damping properties to work properly.

This leading edge technology offers substantial sonic advantages. Among them : very low mechanical energy storage in the cone (so avoiding standing waves) which ensures coherent sound, fast transients, stable sound imaging, high sensitivity, wide frequency range and very-low directivity pattern.

COMPACT MAGNET SYSTEM. Its design has been optimized to obtain maximum transducing efficiency while avoiding nonlinear behavior such as coil inductance variation with position, flux modulation, harmonic distortion, rest position offset, air compression and off-axis voice-coil pushing.

Its design incorporates a T-shaped pole piece, and a flux stabilization ring. It also takes into consideration demagnetization at cold temperatures.

INTERCOOLER SYSTEM (patented). Entirely integrated into the loudspeaker itself, the INTERCOOLER SYSTEM extracts the heat produced by Joule effect in the voice-coil by the means of an air flow directed through the heatsink rims of the basket by the motion of the dust-cap and the spider.

The gain brought about by this technology is over 20 % of extra power, so for example, a 3" coil according to this design has the same power handling capacity as a classical 4" one.



FEATURES

Power handling capacity **160 W AES**
Reference efficiency_(1W @ 1m) **98 dB SPL**
SPL max _(continuous) **116 dB SPL**
Usable frequency range **500-6000 Hz**
Environmental withstanding **Outdoor**

ARCHITECTURAL SPECIFICATIONS

NOMINAL DIAMETER : 166 mm.

FRAME : High tensile alloy pressure die-cast basket with patented INTERCOOLER SYSTEM.

MAGNET SYSTEM : 1.5" highly energized, heat extracting design.

VOICE COIL : High-temperature stabilized copper wire wound on vented, high-strength glass polyimide former.

CONE ASSEMBLY : High-strength cellulose fiber cone impregnated and front-coated with damped resins and fitted with fabric dome and high-speed flat, damped surround.

SPEAKER MASS : 2.15 Kg.

1160

6.5" Midrange Driver

1160

TYPICAL CHARACTERISTICS

Rated impedance	Z	8	Ω
Reference efficiency (1 W@1 m)	-	98	dB SPL
Usable frequency range ¹	-	500–6000	Hz
Power handling capacity ² (AES)	-	160	W
Max Sound Pressure Level ³	SPL _{max}	116	dB SPL
Min. impedance modulus	Z _{min}	6.7 @ 650Hz	Ω
Voice-coil inductance ⁴ @ 1 kHz	L _{e1k}	0.64	mH
@ 10 kHz	L _{e10k}	0.30	mH
Bl product	Bl	10.3	N/A
Moving mass	M _{ms}	0.0076	Kg

THIELE-SMALL PARAMETERS : TYPICAL (QC LIMITS)

Resonance frequency ⁵	F _s	145 (±30)	Hz
DC resistance ⁶	R _e	6.1 (±0.6)	Ω
Mechanical quality factor	Q _{ms}	4.8	1
Electrical quality factor	Q _{es}	0.40	1
Total quality factor	Q _{ts}	0.37	1
Mechanical suspension compliance	C _{ms}	165	10 ⁻⁴ m/N
Effective piston area	S _d	0.0150	m ²
Equivalent C _{as} air load	V _{as}	0.0052	m ³
Max. linear excursion	X _{max}	±1.0	mm
Linear displacement volume	V _d	0.0150	10 ⁻³ m ³
Half-space efficiency		3.7	%
Unity load volume	V _{as} Q _{ts} ²	0.7	10 ⁻³ m ³

ABSOLUTE MAXIMUM RATINGS

Short term max. input voltage ⁷	V _{max}	65	V
Max. excursion before damage	X _{dam}	±2.5	mm
Ambient operating temperature		-10 to +50	°C
Storage temperature ⁸		-20 to +70	°C
Environmental conditions ⁹		Outdoor	

APPLICATION INFORMATION

Air volume occupied by the driver ¹⁰		0.46	10 ⁻³ m ³
Speaker net mass		2.15	Kg
Recommended reflex box	V _b /F _b	3L / sealed	L / Hz
Electrical polarity	A positive voltage applied on the red terminal produces forward cone motion.		

PHYSICAL CHARACTERISTICS

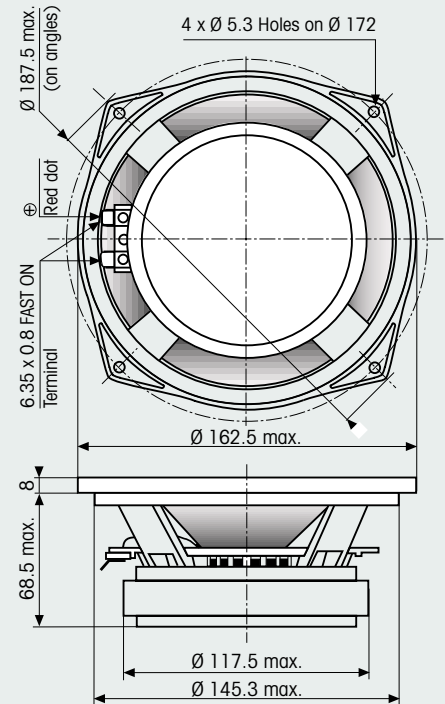

SPECIFICATION NOTES

- Note 1 : Allowing for energy response, excursion capability, Power spectrum, and -3dB low freq. roll-off for standard reflex tuning.
- Note 2 : Established at 20°C ambient temp, according to AES2-1984 standard using IEC268-1 simulated programme signal and a 3 liter sealed test enclosure with a 2nd order high-pass filter @ 800Hz.
- Note 3 : Established at 1m on axis of the loudspeaker mounted in test enclosure, when driven at full AES Power Handling Capacity, including 4dB of thermal compression loss.
- Note 4 : Measured at 20 mA in free air.
- Note 5 : Measured at 20 mA and 20°C ambient temp. in free air conditions, after full run and rest.
- Note 6 : Measured at 20°C ambient temp. QC limits are ±10 %
- Note 7 : Stated in RMS voltage according to IEC 268-5.
- Note 8 : Includes shipping conditions. The lower limit prevents from demagnetization.
- Note 9 : Our products are classified in three categories : Indoor, Outdoor, and Outdoor+ for permanent outdoor use or severe conditions.
- Note 10 : Calculated for front mounting on to a 18 mm thick board.

461, rue des chênes . Z.A
77590 CHARTRETTES
FRANCE

Tél : 33 01 64 81 29 80
Fax : 33 01 60 69 10 28

e-mail : phlaudio@phlaudio.com
http : //www.phlaudio.com